

# BPCADP

## Professional Ball Cart ASSEMBLY INSTRUCTIONS

### BOX CONTENTS

Description	Quantity
• #1 Back frame assembly	1 each
• #2 Bottom frame wheel assembly	1 each
• #3 Side frame pieces with reduced ends	4 each
• #4 Front frame assembly	1 each
• #5 Front Leg assembly	1 each
• #6 Bottom center piece with reduced ends	1 each
• Hardware Kit	

### HARDWARE KIT CONTENTS

Description	Quantity
• "NEVER FLAT" wheels	2 each
• Wheel Washers	2 each
• Wheel Cotter Pins	2 each
• Basket Net	1 each
• Lacing Cord	1 each

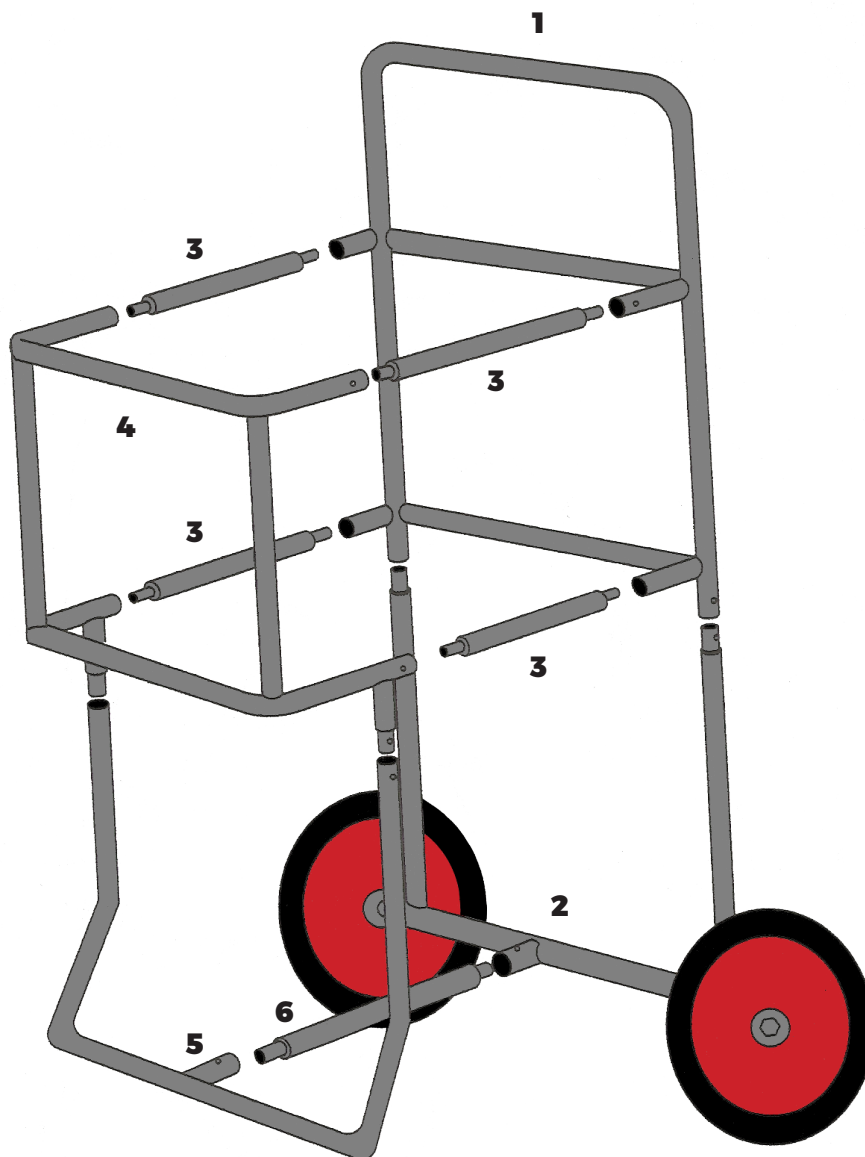

### STEP 1

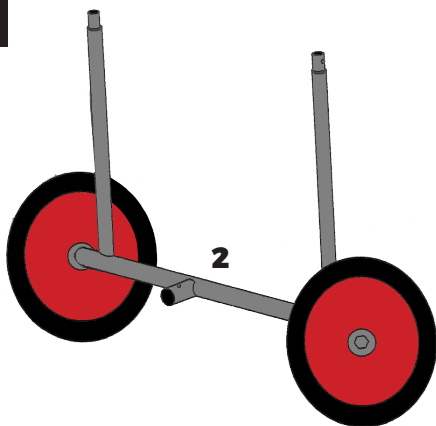

Install (2) Never Flat Wheels to Bottom frame wheel assembly (Part #2). Add Wheel washer to outside of each wheel and secure using Wheel Cotter pins.

**NOTE: Be sure that wheel cotter pins are bent back around center tube for wheel to remain secure.**

### STEP 2

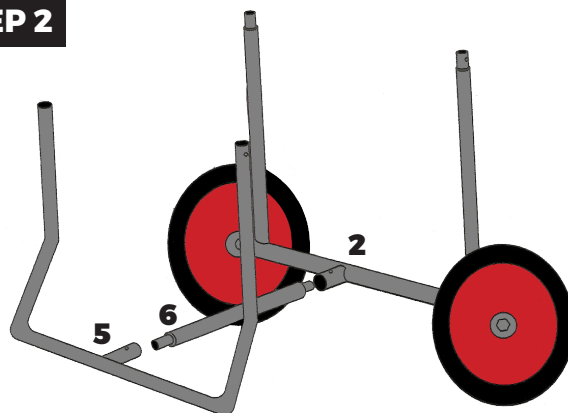

Join Front Leg assembly (Part #5) to Part #2 using Bottom center piece (Part #6) via push button assembly provided.

### STEP 3

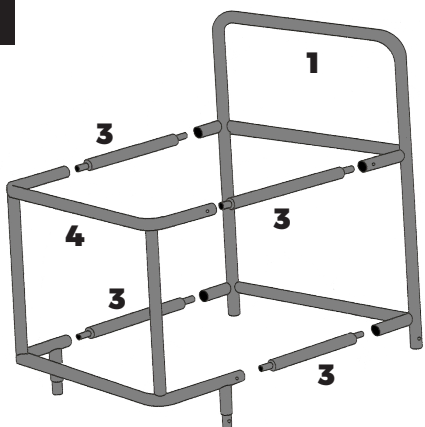

**NOTE: Pre-assemble top portion of ball cart before adding to bottom frame.**

Join front assembly (Part #4) to Back frame assembly (Part #1) using the four side frame assembly pieces (Part #3).

**NOTE: Be sure all push buttons are seated properly.**

### STEP 4



Flip top portion of ball cart upside down on the ground. Attach bottom portion of ball cart to pre-assembled top portion.

**NOTE: If frame is tight you may use a Rubber Mallet to gently tap the assembly in place.**

### STEP 5



Flip ball cart back upright in order to install the net. Be sure net sits squarely and evenly in the center of the basket. Use lacing cord provided to lace top of net to frame first.

**NOTE: Use excess lacing cord to lace bottom portion of the basket to the frame assembly.**

### ASSEMBLED BALL CART

